

## **Earthmoving & Construction**

**Automatic maintenance and safety**





## Groeneveld-BEKA

Reducing customers' operational costs and at the same time increasing uptime, productivity, efficiency and safety of their vehicles and machines. That is what it's all about at Groeneveld-BEKA. We accomplish this by developing, producing, supplying and servicing industry-leading automatic lubrication, fluid control and safety support systems.

Groeneveld-BEKA, part of The Timken Company, is the world's second largest producer of automatic lubrication systems, fluid management and safety support systems. Groeneveld-BEKA products improve equipment life and reliability, while reducing the total cost of ownership.

Groeneveld-BEKA was formed through the merger of two well-established companies: Groeneveld and BEKA. Groeneveld was founded in 1971 and acquired by Timken in 2017. BEKA was founded in 1927 and acquired by Timken in late 2019. Groeneveld has also incorporated Interlube into their brand. Interlube was acquired by Timken in 2013. Groeneveld-BEKA operates in more than 40 countries worldwide and is represented by a growing number of independent distributors in many countries around the globe.

Groeneveld-BEKA products are supplied for ex-factory installs to leading manufacturers of trucks, trailers, buses, wind turbines, industrial applications, mining and construction equipment. In addition Groeneveld-BEKA systems are installed in the after-market for a wide variety of transport, construction, agricultural, port equipment and industrial applications. Groeneveld-BEKA strives to develop and manufacture all of its products in-house according to World Class Manufacturing principles.

### Automatic Lubrication Systems

Groeneveld-BEKA offers dedicated automatic lubrication systems for all kind of equipment in a wide variety of market segments, from the smallest excavator to the largest trucks and industrial applications. The application of our high-end systems leads to decreased wear and tear of critical components resulting in extended life time, less downtime and reduced repair and maintenance costs. In short: higher productivity and lower operational costs. As operators no longer have to climb on or crawl under the equipment, Groeneveld-BEKA's automatic lubrication systems also contribute to safety.

For optimal greasing in all circumstances Groeneveld-BEKA has the right type of grease for every application and every system. This is your guarantee for many years of trouble-free operation of your system and perfect lubrication of your valuable equipment.

### Fluid Control

Groeneveld-BEKA's fluid management systems reduce daily maintenance and minimize the risk of unexpected downtime by controlling engine oil levels or removing contamination. Next to the oil management systems, Groeneveld-BEKA also offers systems which easily convey hydraulic power from a fixed point to a moving point.

### Safety Support Systems

For many years, Groeneveld-BEKA supplies safety support systems for a wide range of applications. Speedlimiters as well as obstacle detection and camera systems by Groeneveld-BEKA increase safety in many segments from road transport to construction, port, terminal and internal transport.

### The World of Lubrication

Groeneveld-BEKA, part of The Timken Company, is a global enterprise with a worldwide coverage. In many countries, the company is also represented by independent distributors and dealers – all just as driven as our own organisation to offer added value to the customer's company.

With decades of experience providing reliability services to a range of industries, Groeneveld-BEKA offers complete automated maintenance solutions for all your needs. Groeneveld-BEKA's reliability products maintain your equipment, helping you increase uptime and improve profitability.

Visit the Groeneveld-BEKA website for contact details of our subsidiaries, distributors and service dealers.

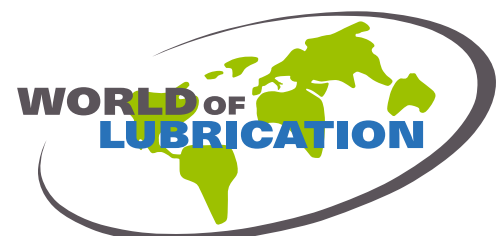

# Automatic maintenance and safety systems for all kind of applications

Indoor or outdoor, extreme high or low temperatures, many or few lubrication points; Groeneveld-BEKA has the perfect lubrication system for every application. Whether it comes to automatic lubrication systems, automatic oil management or safety support systems, Groeneveld-BEKA offers a customised solution for any application in the field of earthmoving and construction.



Telescopic handlers



Backhoe loaders



Crawler loaders



Wheel loaders



Tracked excavators



Wheeled excavators



Rigid dump trucks



Articulated dump trucks



Dozers & Graders



Asphalt finisher

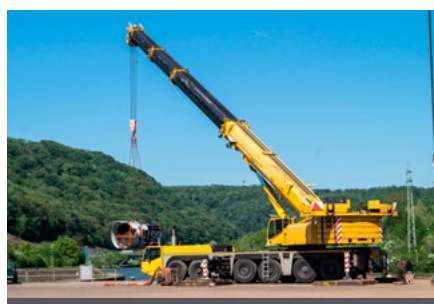

Mobile cranes



Attachments

## Less maintenance, improved efficiency and lower costs.

Manual lubrication of pins and bushings, for example, is not only dirty and unpleasant work, it also takes time. Time during which the machine should be in operation to make money. Because in the end it is all about profitability.

Groeneveld-BEKA's systems have been proven to extend component life compared with manual greasing, dramatically cutting the cost of component replacements, reducing machine downtime and improving efficiency and safety.

### The benefits

The benefits of automatic lubrication are clear: a better greasing of critical components, no time wasted on manual lubrication and the certainty that machines will always be greased independent of weather conditions, time schedules or operators. All resulting in significant cost savings.

#### Reduced man-hours required to lubricate

- Improved availability of maintenance personnel for other technical activities.
- Reduced lubricant spillage that occurs with manual lubrication.

#### Higher equipment productivity

Reduced vehicle downtime by ca. 15% resulting from:

- Lubrication taking place during normal vehicle operation.
- Better and uniform greasing of all critical components because bearings and pins and bushings are in motion when lubrication takes place, resulting in less wear and tear.

#### Decreased maintenance

- With manual lubrication, grease will follow the path of least resistance due to the fact that greasing has to take place under static conditions. So, the grease is not equally distributed around the lubrication point. Automatic greasing avoids this, as lubrication will take place during operation, reducing wear of critical components.
- Reduced replacement rate of components and bearings up to 50%.
- Decreased machine labour costs by ~ 50%.

#### Improved safety

- No climbing on or crawling under machines or inaccessible areas.

## Effectiveness of Automatic Lubrication

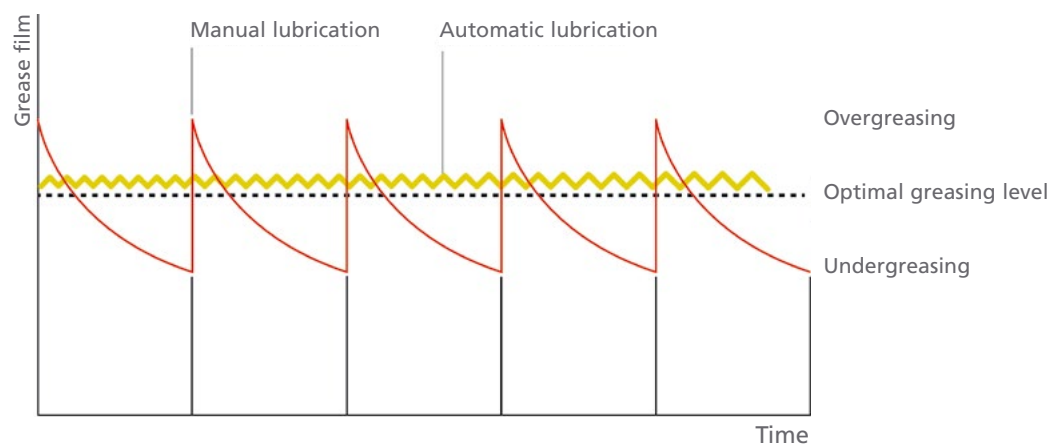



# **Automatic lubrication systems**

**Less maintenance, improved efficiency**



## Groeneveld MultiLine

The Groeneveld MultiLine is a range of automatic lubrication systems mainly designed for self-install on mini excavators and compact dump trucks. It enables the use of automatic lubrication on applications where return on investment is challenging.

The MultiLine self install kits are ready to be installed by your own technicians. You can select a reservoir of 1.25 and 2 liter. With all of the greasing points lubricated automatically, the service interval and lifetime of the application are extended significantly. This makes the MultiLine a smart investment in operational efficiency.

- Suitable for oil SAE 80/90 up to NLGI-2 grease
- All fittings are standard with push-fit connectors
- Lines are numbered, pre-cut and grouped
- Reduces operational costs and increases efficiency
- Waterproof and corrosion resistant

### System overview



#### Fill cap

The MultiLine oil pumps are fitted with a bulk fill cap which is suitable for oil fill.

#### Reservoir with paddle blade

The reservoir is equipped with a paddle blade which pushes the lubricant into the pumping chamber and provides a visual indication of the pumps operation.

The MultiLine is available in 1.25 or 2 litre reservoir.

#### Pumping elements

MultiLine AC is available with up to 60 pumping elements. The MultiLine AC pumps are pre-calibrated with yellow 0.025 cc pumping units.

If a lubrication distribution line is not required simply remove the line and replace it with a blanking plug.

#### Filler coupling

At the bottom, the pump is equipped with a grease nipple for filling with grease. Using the grease nipple adaptor for grease fill avoids the possibility of air entrapment and cavitation.

#### Push fit connectors

The push fit connectors provide an easy installation of the lubrication lines.

### Pumping elements

A selection of pumping elements with varying outputs are available to suit almost any need. Each pumping element has a push fit connector to provide an easy installation of the lubrication lines.

The maximum output pressure of each pump element is 120 bar (1740 PSI).

Color	Output/stroke	Outlet size
Red	0.010 cc	4 mm OD Push type
Green	0.015 cc	
Yellow	0.025 cc	
Blue	0.040 cc	
Grey	0.060 cc	
Black	0.100 cc	

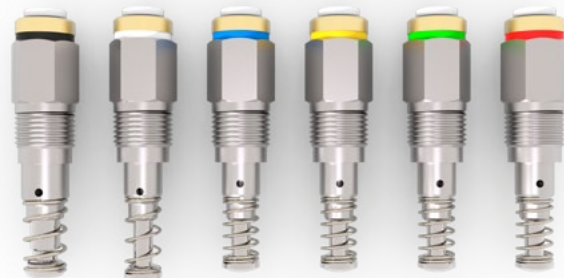



## Groeneveld SingleLine

The combination of a strong and reliable pump and a wide range of unique metering units makes the SingleLine a highly suitable system for heavy transport equipment or mobile cranes.

Independent of ambient temperature and grease viscosity, the system will apply exactly the pre-set amount of grease at each lubrication point. Long lines and large numbers of lubrication points do not pose a problem for this high quality system. The system is available in both an electrical and pneumatic version.

The system works with a relatively low pressure, preventing separation of the grease. The patented volumetric metering units ensure that the grease metering per lubrication point can be perfectly adjusted to the demand of the part to be lubricated.

- Optimum lubrication and sealing of all lubrication points
- Easy to install and to extend, quick couplings allow easy expansion of the system
- The unique metering units offer an exact and adjustable amount of grease per lubrication point
- Filler coupling with filter in order to prevent contamination of the grease during filling
- Optionally equipped with a level indicator in the grease reservoir with an active warning

### System overview



#### Follower plate

The follower plate ensures that all the grease in the reservoir is used. This means that the reservoir wall remains clean, allowing you to check the grease level visually. Ageing of the grease as a result of oxidation is also prevented.

#### Reservoir

The Groeneveld SingleLine is available with reservoir volumes of 4, 6 and 8 litres.

#### Filler coupling with filter

The filling coupling with an internal grease filter prevents contamination of the grease during filling.

#### Pump housing

The pump is made of hard anodised aluminium and nylon reinforced - containing the control unit, memory database and minimum level indicator.



## BEKA Stream

The powerful BEKA Stream is designed to provide lubricant within a central lubrication system or to single lubrication points, independent of ambient temperatures. The BEKA Stream is the ultimate solution for large applications requesting a larger amount of lubricant and is suitable for EP greases up to NLGI-2.

The system works with a relatively low pressure, preventing separation of the grease. The combination with the unique single line metering injectors ensure that the metering per lubrication point is perfectly adapted to the application.

The use of wear-resistant materials makes the seals uniquely resistant like no other on the market. This pump is not only the perfect partner in the mining sector, where tough and rough operating conditions prevail. Even when operating with lubricants containing solids, the maintenance effort remains low and simple thanks to the user-oriented design.

The Stream is available in both an electrical and hydraulic version and can be ordered together with a container or barrel. Here, optional fill level monitors ensure that refilling with lubricant can be perfectly planned.

- Available with an Electric (Stream E) or Hydraulic (Stream H) motor
- Robust construction ensures reliable use in mining and outdoor applications
- High delivery capacity, perfectly suitable for large applications
- Reliable lubricant supply even at extreme ambient temperatures
- Available with a wide range of reservoir capacities, as container version or barrel pump
- Easy to maintain because no oil change is necessary

### System overview



Stream E

**Electrical motor**

**Pressure outlet and return connection**

The integrated return connection offers the possibility to return grease into the grease container during the relief sequence or in case the pressure safety valve opens. Therefore, the grease stays in the system only for a short time before being sucked into the system again.

The return connection can also be used for refilling the container.

**Mechanical level indicator**

**Overfill protection**

The overfill protection helps to avoid possible pump damages due to overfilling.

**Grease container with follower plate**

An follower plate with an intelligent follower piston contour in the container ensures that no air is sucked into the container. It also ensures that all the grease in the reservoir is used and prevents oxidation of the grease.

**Filling connection**

The filling connection makes it possible to fill up the grease container with use of a filling pump.

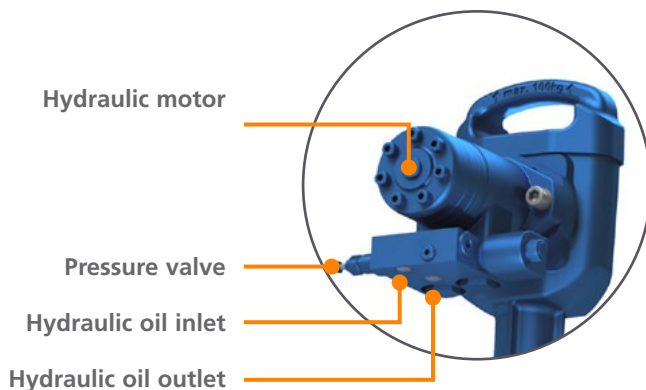

**Hydraulic motor**

**Pressure valve**

**Hydraulic oil inlet**

**Hydraulic oil outlet**

Stream H

## Groeneveld Twin

Unique product features make the Twin the best solution for larger machines that are often used under extreme conditions. The system works under relatively low pressure, which means that the structure – and therefore the quality – of the grease is preserved.

The dual-line system with its patented metering units ensures that all lubrication points are always optimally lubricated. This is made possible due to precise metering and lubrication intervals, also in case of extremely low or high ambient temperatures and large distances between pump and lubrication points. In addition, it is easy to expand the system to detachable equipment pieces. This makes the system extremely suitable for larger machines such as large wheel loaders and dump trucks, but also for spreaders and heavy haulage trailers.

- Grease output and grease delivery independently of ambient temperature and grease viscosity
- Thanks to the relatively low work pressure, the quality of the grease is preserved
- Modern pump with real-time clock, memory, CAN-Bus connection and follower plate
- Suitable for biodegradable grease
- High quality metering units and distribution blocks
- Standard with in-cab display
- Available with reservoir volumes ranging from 2 to 200 litres
- Easy to program, install and extend
- The filling coupling with filter prevents contamination during filling
- Easily extended to grippers, excavation buckets and other equipment pieces through quick couplers

### System overview



#### Follower plate

The follower plate ensures that all the grease in the reservoir is used. This means that the reservoir wall remains clean, allowing you to check the grease level visually. Aging of the grease as a result of oxidation is also prevented.

#### Reservoir

Twin is available with reservoir volumes of 3, 4, 6 and 8 litres.

#### Filler coupling with filter

The filling coupling with grease filter prevents contamination during filling.

#### Pump housing

The pump is made of hard anodised aluminium and nylon reinforced - containing the control unit, memory database and minimum level indicator.

### Twin XL & Twin barrel pump

Specifically for larger applications, the Groeneveld range includes the Twin XL with an extra large reservoir of 20 litres. An automatic lubrication system with a higher grease delivery and an extra large reservoir, made of sturdy and coated material.

For machines and vehicles with an extremely high grease demand, such as mining equipment, Groeneveld supplies reservoir volumes from 40 to 200 litres.

Major benefit will be that the user rarely needs to refill the reservoir.



Twin XL

## BEKAMAX ZEPTO

The electric cartridge pump ZEPTO is designed to provide lubricant within a central lubrication system (for example, a progressive system) or to single lubrication points. ZEPTO is mainly used for lubrication of smaller machines and systems with up to 30 lubrication points.

The compact eccentric pump supplies the lubricant reliably with the help of a desmodromic pump element. An innovative revolution control ensures constant delivery rates irrespective of the supply voltage.

ZEPTO can be used with various screw cartridge types available on the market. Due to simple cartridge replacement the lubricant can be refilled fast and clean.

- Rugged and compact design
- Simple replacement of lubrication cartridge without tools
- Suitable for various screw cartridge types available on the market
- High-strength glass fiber plastics withstand the most adverse conditions
- Unique: dust tightness (6K) and safe cleaning through high pressure/steam jet cleaning (9K)

### System overview



#### Protective cover

The cartridge is protected by a transparent cover.

#### Cartridge types

Suitable for different cartridge types for greases up to NLGI-2. ZEPTO is as standard being delivered with a cartridge adapter type S.

#### Pump element

Pump element incl. pressure limiting valve and a  $\varnothing$  6 mm pressure connection. The pump element has a constant output of 0.9 cc per minute, regardless of the supply voltage.

#### Display

All programs and parameters of the device can be set directly with the control keys on the display under the inspection glass. No additional tools are needed.

#### Integrated control unit

The ZEPTO has an integrated control and is available in two versions.

The operational modes are time control, time control with pressure monitoring, pulse control and continuous operation.



# BEKAMAX PICO

The PICO system combines power and flexibility in perfect conditions with a compact design. The PICO system is the unique combination of progressive- and multi line technology.

The basic version of the PICO pump supplies lubricant through the progressive outlets to the lube points via one or more progressive distributors. In addition up to 8 lubrication points can be supplied directly via the multi line principle. If necessary the system can be enlarged by a second progressive cycle.

- Very compact design for applications with little number of lubrication points
- Unique combination of two lubrication systems:
- Progressive- and multi line technology
- Suitable for all common lubricants from NLGI-000 up to NLGI-2
- Flexible extension possibilities

## System overview



### Reservoir

The 1,2 litre reservoir is available with agitator blade or follower plate. The system with a follower plate can be installed in each direction, also upside down.

### Follower plate

The follower plate ensures that all the grease in the reservoir is used. This means that the reservoir wall remains clean, allowing you to check the grease level visually. Ageing of the grease as a result of oxidation is also prevented.

### Multi line outputs

The PICO has got 8 multi line outputs for different pump elements.

### Progressive outputs

The PICO has got 2 progressive outputs for different pump elements.

### Filling zerk

The pump can be filled with a standard filling gun. The filling zerk can be replaced by a filling connection to refill using a filling pump.

### Control unit

The PICO can be delivered with an integrated control unit with:

- 3 control functions: time, stroke or revolutions
- Electronic monitoring of grease level, pump function, distributor function, line rupture, lubricant feeding
- Selection of operating conditions: easy, medium or heavy
- Integrated data logger with diagnosis module DiSys

The protective housing is equipped with a bayonet or Hirschmann plug-type connection.

## Pump elements

Two different construction types of pump elements can be installed into the device, depending on for which lubrication system or for which lubrication system combination the device is used.

System	Pump elements		Metering volume
Multi line	PE 5		0.005 cc/stroke
	PE 10		0.010 cc/stroke
	PE 15		0.015 cc/stroke
	PE 25		0.025 cc/stroke
	PE 50		0.050 cc/stroke
Progressive	PE 120 F	with/without pressure limiting valve	0.120 cc/stroke
	PE 120 FV		0.04 up to max. 0.12 cc/stroke (adjustable)

## BEKAMAX EP-1

The EP-1 is an electrically actuated pump with up to 3 lubrication outlets. The EP-1 is able to deliver commercial lubricants from NLGI-000 up to NLGI-2 at a working pressure of maximum 280 bar. Therefore this system is the ultimate solution for different applications in the construction industry.

- A versatile solution for most mobile and stationary applications
- Suitable for all common lubricants
- Springless pump elements with desmodromic drive for highest reliability

### System overview



#### Level monitor

The EP-1 can be equipped with an electronic grease level controller to control the minimum grease level.

#### Reservoir

The EP-1 reservoir is made of transparent plastic and contains an agitator blade. The agitator blade enables a visual check of the lubricant volume in the reservoir.

EP-1 is available with different reservoir capacities.

#### Pressure relief valve

#### Pump element

The EP-1 has up to a maximum of 3 lubricant outlets. A separate pump element is required for each outlet. Three pump elements with different flow rates are available, as well as a flow-adjustable pump element.

#### Filling zerk

The pump can be filled with a standard filling gun. The filling zerk can be replaced by a filler coupling.

#### Control unit

The EP-1 series differ in control type. EP-1 can be controlled externally or with an integrated control unit with:

- 3 control functions: time, stroke or revolutions
- Electronic monitoring of grease level, pump function, distributor function, line rupture, lubricant feeding
- Selection of operating conditions: easy, medium or heavy
- Integrated data logger with diagnosis module DiSys

### Pump elements

Three pump elements with different flow rates are available, as well as a flow-adjustable pump element. All pump elements are marked either with a groove or with a notch for a better differentiation.



PE 60 PLV  
0.06 cc/stroke



PE 120 PLV  
0.12 cc/stroke



PE 120 V PLV  
Max. 0.12 cc/stroke  
Adjustable output



PE 170 PLV  
0.17 cc/stroke

Pressure: Max. 350 bar  
Pressure limiting valve: adjusted to 280 bar

## GROENEVELD TRIPLUS

The Groeneveld TriPlus is a unique progressive lubrication system that offers three circuits that can be operated independently. It is the ultimate solution for machines that have different components requiring different amounts of lubrication. This prevents unnecessary lubrication of components that are not moving.

- Three lubrication circuits that can be operated independently
- Grease metering regardless of the ambient temperature
- Optimal grease metering per lubrication point
- Follower plate for visual checking of the grease level and to prevention of ageing of the grease as a result of oxidation
- Filling coupling with filter prevents contamination during refilling
- Provided with in-cab check light

### System overview

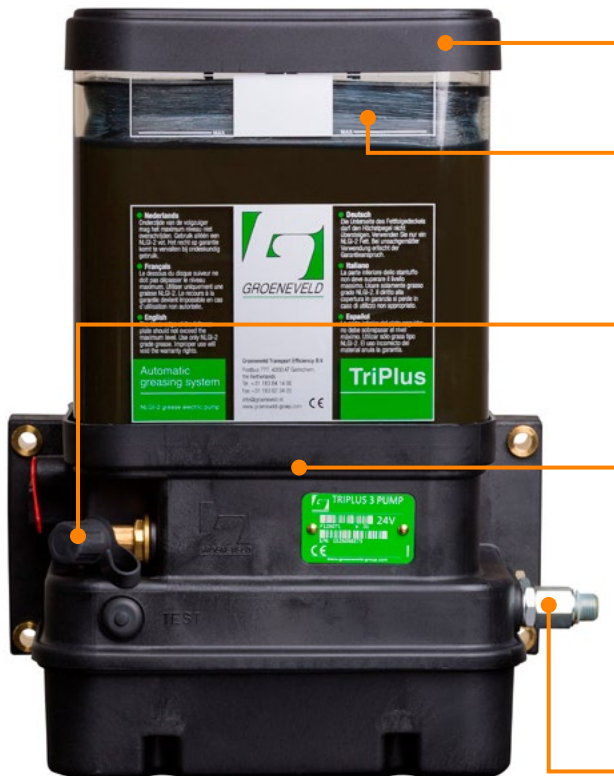

#### Reservoir

TriPlus is available with reservoir volumes of 1,5, 3, 4, 6 and 8 litres. The 6 and 8 litre pumps are equipped with a round reservoir.

#### Follower plate

The follower plate ensures that all the grease in the reservoir is used. This means that the reservoir wall remains clean, allowing you to check the grease level visually. Ageing of the grease as a result of oxidation is also prevented.

#### Filler coupling with filter

The filling coupling with grease filter prevents contamination during filling. To be able to fill the reservoir using a special filling pump, a special filler coupling can be installed.

#### Pump housing with integrated control unit

The pump is made of hard anodised aluminium and nylon reinforced - containing the control unit, memory database and minimum level indicator.

The controller is the core of the TriPlus. This electronic controller, with a real-time clock and memory, ensures that each lubrication circuit receives the exact amount of grease that has been programmed. These settings can always be adjusted to changing working conditions.

#### Outlets

The TriPlus can be delivered with up to 3 separate grease outlets with independent programming.



## BEKAMAX GIGA

The BEKA GIGA range is like having four pumps in one! It serves the full range of automatic lubrication systems and can be used as a progressive as well as a single line, dual line or sectional system. The progressive system is the most commonly used layout.

The GIGA has three independent outlets for lubricant supply that are tied together by internal channels within the pump housing. Each channel can be used for a different section (with its own pump element) and set to a unique cycle, or they can all be combined to one lubrication circle with a higher delivery rate.

The optional GIGA-multitronic control unit can control and monitor up to four modes of lubrication.

- Suitable for all lubrication systems: single line, dual line, progressive and sectional
- Three lubrication circuits that can be operated independently
- Grease metering regardless of the ambient temperature
- Available in different reservoir sizes; 4, 8 or 16 litre

### System overview

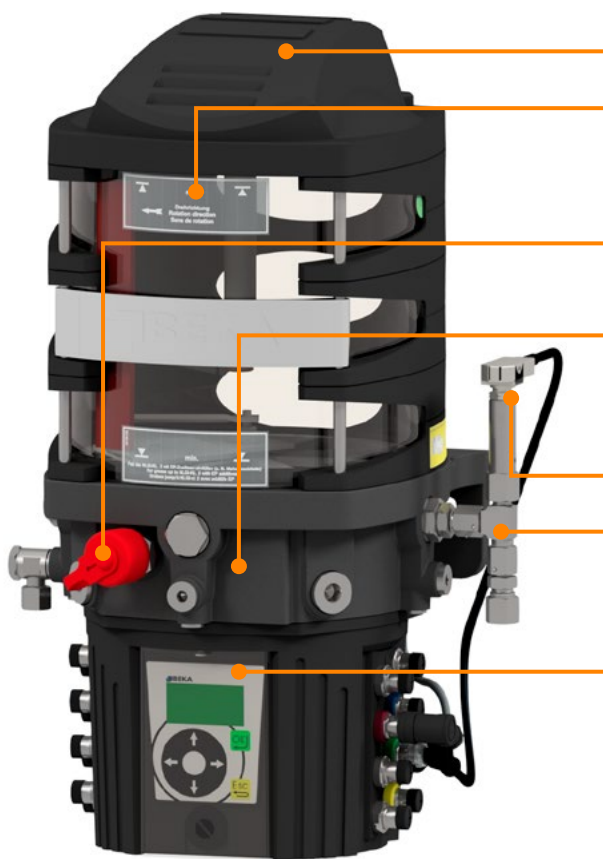

**Reservoir cover**

**Reservoir**

The GIGA is available with reservoir volumes of 4, 8 and 16 litre. All reservoirs contain a agitator blade which enables a visual check of the lubricant volume in the reservoir.

**Filling port**

The pump can be filled with a standard filling gun.

**Pump housing**

The delivery volume of the GIGA can be varied by combining the outlets to one due to the special pump body with integrated channels.

**Pressure relief valve**

**Pump element**

The GIGA has up to a maximum of 3 independently operating lubricant outlets. A separate pump element is required for each outlet. Two pump elements with different flow rates are available.

**Controller with motor housing**

There are 3 different housings available:

- A version without control
- A version with the GIGA-tronic
- A version with the GIGA-multitronic control unit.

### Pump elements

Two pump elements with different flow rates are available for the GIGA range. Both elements are available with or without a pressure limiting valve.



PE 120G PLV  
0.12 cc/stroke and outlet



PE 250G PLV  
0.25 cc/stroke and outlet



## BEKA HAMAX

Hydraulic breakers are highly-stressed add-on tools for construction machines and need to be supplied with special lubricants to reduce wear and tear of the chisel. The BEKA HAMAX offers a complete range for hydraulic breakers or other construction machinery attachments.

BEKA's HAMAX breaker lubrication systems guarantee the steady lubrication of highly loaded bearing points. Due to the special design of the pumps it is even possible to deliver lubricants with high solid additives like copper.

- Effective reduction of wear and tear
- Higher productivity without separate lubricating services
- Trouble free operation with heavy duty components
- Reliable even with low temperatures
- Suitable for special lubricants
- Installation at the breaker - ideal for the use with different machines

### System overview HAMAX-2 & HAMAX-2 Compact

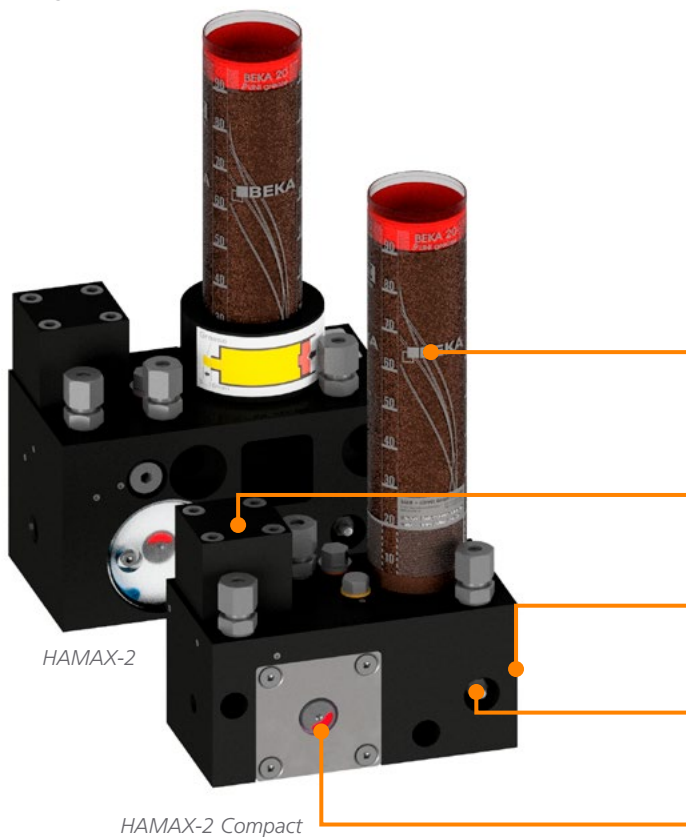

#### Grease cartridge

The HAMAX-2 and HAMAX-2 Compact are suitable for different grease cartridge types for EP-grease without solids or chisel pastes up to NLGI-2.

#### Hydraulic motor

Since the device is driven by a hydro motor a continuous lubricant delivery is ensured.

#### Pump element

The HAMAX-series have an integrated and exchangeable pump element.

#### Grease zerk

A grease zerk is integrated for manual lubrication in case of a failure of the hydraulic system.

#### Visual operating indicator



## HAMAX-11

HAMAX 11 is mainly used to lubricate hydraulic hammers or other construction machinery attachments. Due to its compact design, it can be mounted directly at the attachment. For operation, the grease pump is connected with a bypass line to the hydraulic pressure line of the carrier.

HAMAX 11 is designed that with each hydraulic pulse one lubricant stroke is carried out. The delivery rate is adjustable with a setscrew. Three different types of reservoir sizes are available. The grease level control is carried out visually by the level indicator pin.

### System overview

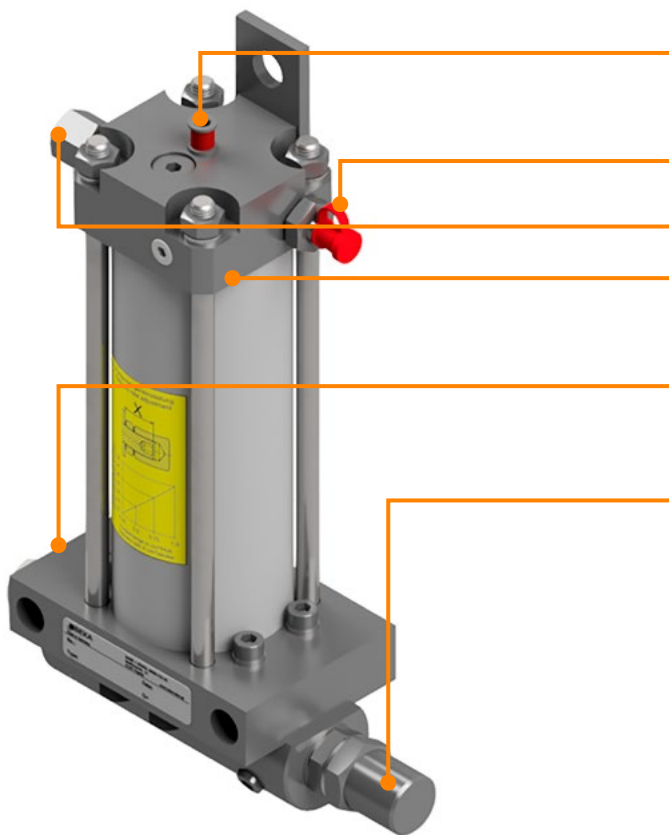

**Level indication pin**

If the grease reservoir is empty, the level indication pin will be visible.

**Filling zerk**

**Outlet**

**Grease reservoir**

The HAMAX-11 is available with reservoir volumes of 0.1, 0.2 or 0.4 litre.

**Hydraulic connection**

The hydraulic connection of the pump can be connected via a bypass line to the hydraulic system of the supporting device.

**Output adjusting screw**

The output rate is infinitely variable from 0.25 cc up to 1 cc per stroke via the adjustment screw.



## BEKA FKGM-HP

The BEKA-MAX FKGM-HP is a hydraulic actuated pump and used for lubrication of an hydraulic hammer, installed on the excavator itself to protect the pump.

- Installation directly at the excavator to protect the pump
- Suitable for greases up to NLGI-2 and chisel paste
- Available in different reservoir sizes, transparent plastic or steel
- Lubricant output from 0.12 up to 0.17 cc per stroke

### System overview

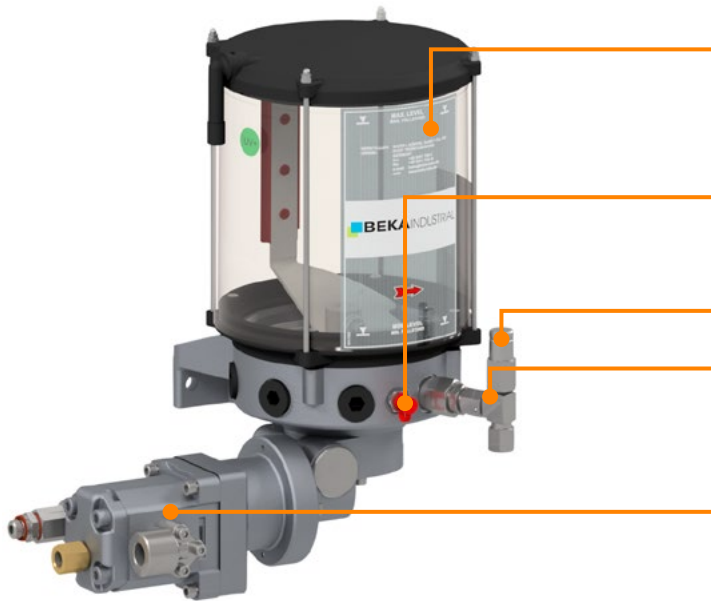

#### Grease reservoir

The FKGM-HP is equipped with an agitator blade. The pump is available with 4 transparent reservoir sizes and with 2 steel reservoir sizes.

#### Filling zerk

The pump can be filled with a standard filling gun. The filling zerk can be replaced by a filler coupling.

#### Pressure relief valve

#### Pump element

A separate pump element is required for each outlet. Three pump elements with different flow rates are available, as well as a flow-adjustable pump element.

#### Hydraulic motor

The speed of the hydraulic driven gear motor is regulated via the flow of the drive medium. The number of revolutions can be adjusted.

### Pump elements

Three pump elements with different flow rates are available, as well as a flow-adjustable pump element. All pump elements are marked either with a groove or with a notch for a better differentiation. Special versions are available for the use of grease with solid contents.



PE 120 PLV  
0.12 cc/stroke



PE 120 V PLV  
Max. 0.12 cc/stroke  
Adjustable output



PE 170 PLV  
0.17 cc/stroke

Pressure: Max. 350 bar  
Pressure limiting valve: adjusted to 280 bar

## BEKA HPG-2

The hydraulic grease pump HPG-2 is an automatic lubrication system which, thanks to its robust and compact design, is particularly suitable for use in progressive centralized lubrication systems. The HPG-2 is the ideal solution for greasing of attachments of construction machinery or agricultural applications.

The HPG-2 is designed for the delivery of NLGI-1 and NLGI-2 multi-purpose grease. The use of standard grease cartridges enables quick and clean refilling.

- Robust and compact design for use with progressive centralized lubrication systems
- Ideal solution for attachments
- Suitable for different grease cartridge types, NLGI-1 and NLGI-2
- Equipped with a MX-2 type progressive distributor
- Suitable for up to 20 lubrication points

### System overview

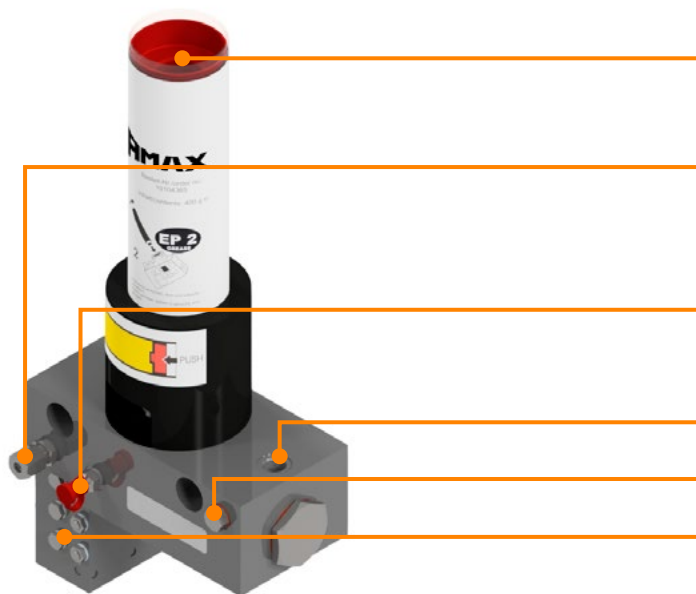

#### Grease cartridge

The HPG-2 is suitable for different grease cartridge types for EP-grease up to NLGI-2.

#### Lubricant outlet

If a lubrication point needs a higher dosage it is possible to combine several metering elements and deliver the grease to the pumps separate lubrication outlet.

#### Filling zerk

A grease nipple is integrated for manual lubrication in case of a failure of the hydraulic system or to prefill the system.

#### Hydraulic connection

#### Hydraulic ventilation

#### Progressive distributor

The HPG-2 is equipped with a MX-2 progressive distributor. The number of elements as well as the metering volume can be adjusted to the application.

### Progressive divider MX-2

The progressive distributor MX-2 is installed at the hydraulic pump HPG-2. The MX-2 contains minimum three and maximum 10 metering elements and one end element, that are combined to one distributor block. Each element has 2 outlets.

Metering element	Output per outlet	Output per element
MX-2 25	0.025 cc	0.050 cc
MX-2 45	0.045 cc	0.090 cc
MX-2 75	0.075 cc	0.150 cc
MX-2 105	0.105 cc	0.210 cc

## BEKA HPM-2S

The BEKA HPM-2S grease hydraulic pump is a centralized lubrication pump which, thanks to its robust and compact design, is particularly suitable for use in progressive centralized lubrication systems on attachments such as drilling machines, front loaders and other hydraulic equipment.

The HPM-2S hydraulic grease pump is designed for pumping NLGI-2 multi-purpose greases. The use of standard grease cartridges type S, which are screwed directly into the pump housing, enable quick and clean refilling.

The HPM-2S hydraulic grease pump can be combined with progressive distributors.

- Delivers lubricant dose with each impuls of the hydraulic system
- Adjustable output rates to suit equipment and application
- Suitable for NLGI-2 grease cartridge type S
- Output from 0.2 up to 2.0 cc/stroke

### System overview



#### Grease cartridge

The HPM-2S is suitable for NLGI-2 grease cartridge type S without solids.

#### Lubricant connection

Ventilation screw hydraulic oil

#### Hydraulic connection

#### Set screw

The delivery rate can be set progressively via the setscrew for the delivery rate within a range from 0.2 to 2.0 cc/stroke.

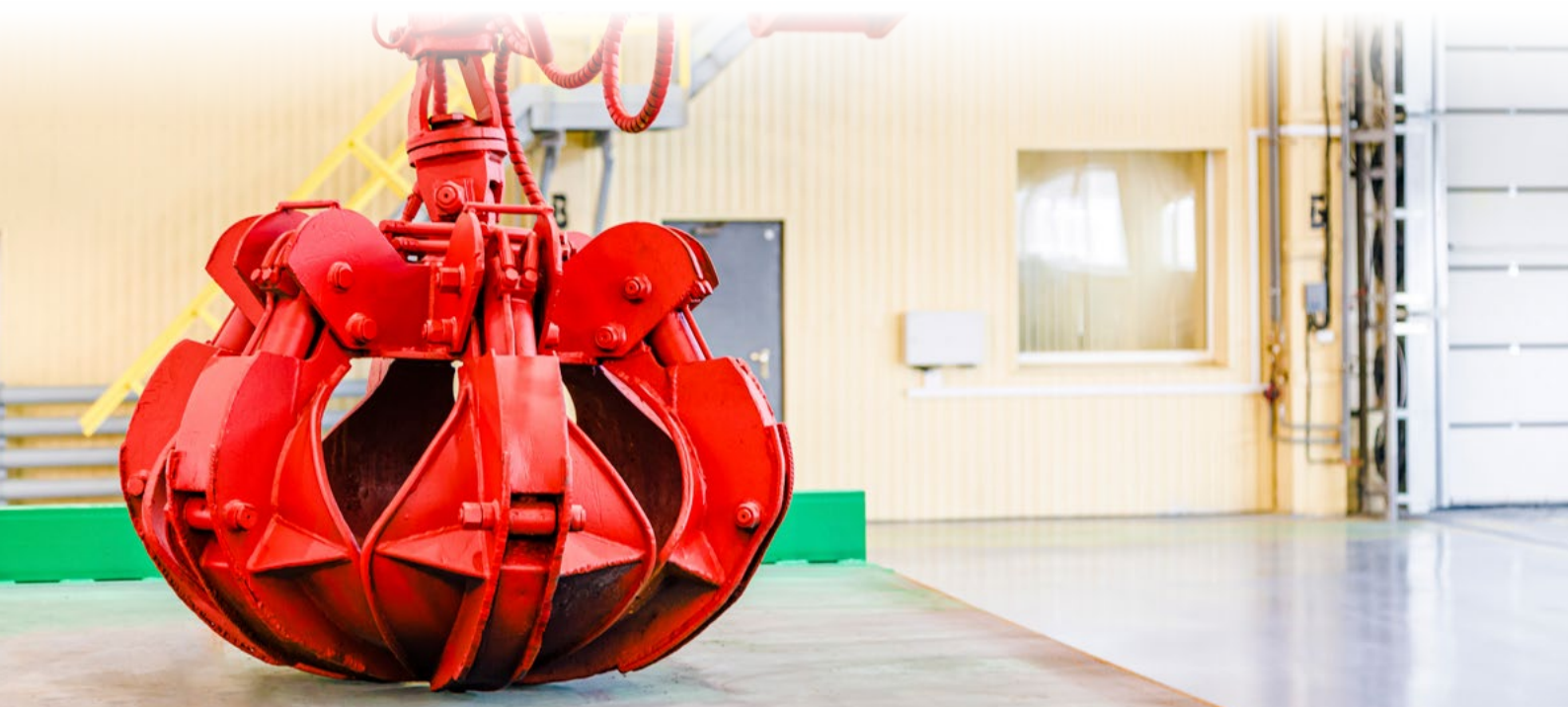

# Advised lubrication systems per application

Application	Multi Line System	Single Line System		Dual Line System		Progressive System				
	MultiLine	SingleLine	Stream	Twin	Twin XL	ZEPTO	PICO	EP-1	TriPlus	GIGA
Telehandlers				●				●		
Wheel loader (<15 tons)				●				●		
Wheel loader (15-50 tons)				●				●		
Wheel loader (>50 tons)			●		●					
Articulated dump truck				●				●		
Rigid dump truck				●				●		
Dump truck (<60 tons)				●						●
Dump trucks (>60 tons)			●		●					
Mini excavators (<6 tons)	●					●	●			
Tracked excavators (6-15 tons)				●				●		
Tracked excavators (15-100 tons)				●				●		●
Tracked excavators (>100 tons)			●		●					●
Wheeled excavators				●				●		
Compact dump trucks	●					●	●			
Dozers & Graders (<35 tons)				●				●		
Dozer & Graders (>35 tons)			●	●						
Mobile crane		●						●		
Mobile crane incl. chassis		●						●	●	

Application	HAMAX	HPM-2S	HPG-2	FKGGM-HP	EP-1					
Hydraulic hammer	●			●	●					
Grabber / Loading bucket		●	●							

- Advised system
- Alternative system

# **Fluid control systems**

**Enhancing performance**



## Groeneveld Oilmaster

With the Oilmaster, daily oil level checks and topping-up engine oil are no longer required. Oilmaster automatically checks the oil level according to an engine specific protocol and tops-up the oil from the integrated reservoir when needed. As a result the engine oil is always exactly at the right level. Not too low, but certainly not too high either. Oilmaster saves oil, time and costs, whilst reducing machines environmental impact.

- Manual oil level checks and filling oil are history - pure time saving
- Always the optimum oil level and the right oil specification
- No engine damage as a result of a too low oil level
- Less unscheduled downtime for repairs and maintenance
- Less risk of damaging the exhaust gas aftertreatment system
- Decreased oil consumption
- Avoiding increased fuel consumption as a result of overfilling
- Less oil needed at an oil change and less oil waste
- Lower costs
- Care for the environment

### Always the right oil level

Oilmaster, the advanced oil management system, ensures that the engine oil is always at the right level. Not too low, which can cause serious engine damage and also not too high, which can lead to excessive oil consumption, oil leakages or blown-out seals, increased fuel consumption and even damaged exhaust gas after treatment systems. As the oil is topped-up from the integrated tank, it also reduces the risk of operators adding oil of the wrong specification.

Oilmaster guarantees maintenance employees and management can minimise the risks of major repair and standstill as a result of damage to engines. This is comfort by security! Oilmaster provides increased business security, maximum availability of the equipment and consequently a short cost-recovery period.

### System overview

#### Control unit

The control unit controls and monitors all actions performed by the Oilmaster system.

When during a measurement the sump level sensor detects a valid low level in the engine sump, the control unit starts a pump cycle.

#### Calibration tank

During one pump cycle the whole contents of the calibration reservoir (0.5 litres) will be added to the oil in the engine. The quantity of oil added during a single pump cycle is always the same.

#### Additional options:

- Can-BUS interface
- Inclination sensor
- Visual main-tank level indicator
- USB diagnosis connector

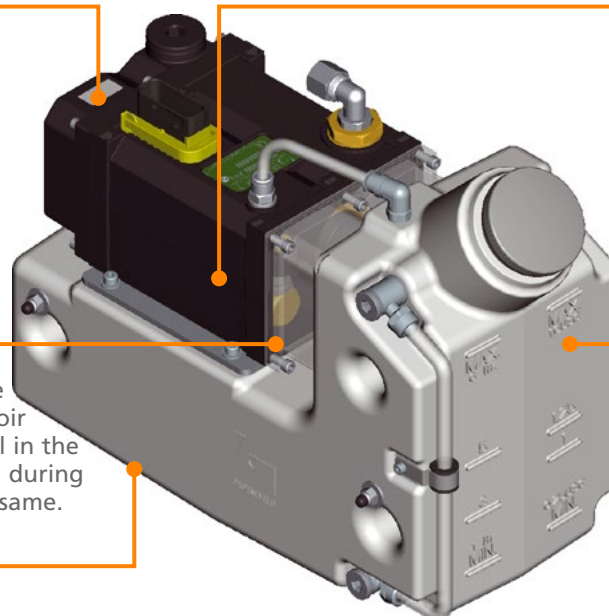

#### Tilt sensor

The tilt sensor ensures that the Oilmaster will only measure the oil level at the moment the engine is levelled.

It also measures the oil level only after an adequate period for oil level stabilisation.

#### Main reservoir

The Groeneveld Oilmaster is available in 6, 12 and 19 litre versions. Reservoirs can be adapted to special OEM requirements.

For the most demanding applications a heavy duty Oilmaster with a solid 15 litre aluminum tank is available.



## Groeneveld Filtakleen

The Filtakleen is an ultra-fine bypass filtration system suitable for use on a wide range of equipment. It provides the best possible filtration protection against system wear, oil degradation and corrosion. Working in conjunction with the equipments full flow filter, the Filtakleen by-pass filter removes any particles in the oil likely to cause system damage.

The Filtakleen typically filters all the oil in the system several times an hour, so the system continuously receives analytically clean oil.

- Enhances oil performance
- Improves reliability
- Ultra fine particle removal to ISO 17/15/12 - NAS6
- Prevents corrosion by removing 100% of water from oil
- Prevents system wear
- Prevents acidity in oil

### Significantly extending oil life

The by-pass filter is designed to be used in conjunction with the main in-line-filter. The system continuously filters a percentage of the oil (typically 10 %) in the circuit which means it is able to provides additional filtration to a much finer tolerance than the in-line filter. This greatly prolongs the life of both the oil and the main filter itself.

The filter housing is manufactured as a one piece aluminium anodised body, which is powder coated. Making it a durable solution for all kind of environments. The lid is secured by a single high tensile bolt which makes lid removal and filter changing quick and easy. The lid houses a quad ring seal, giving completely leak proof sealing.

The filter cartridge is made from a cellulose fibre based tissue of pure pulp, around a cardboard core. The cartridge is housed in a nylon stocking with an impressed brass ring to facilitate cartridge removal. The filter housing is fitted using an adjustable mounting bracket, which offers the installer a wide range of filter positions and fixing points.

The filter is capable of filtering all types of oils with a viscosity range of 9 - 220 cSt. It is also suitable for use with other mediums such as bio fuels and dielectric fluid.

### System overview

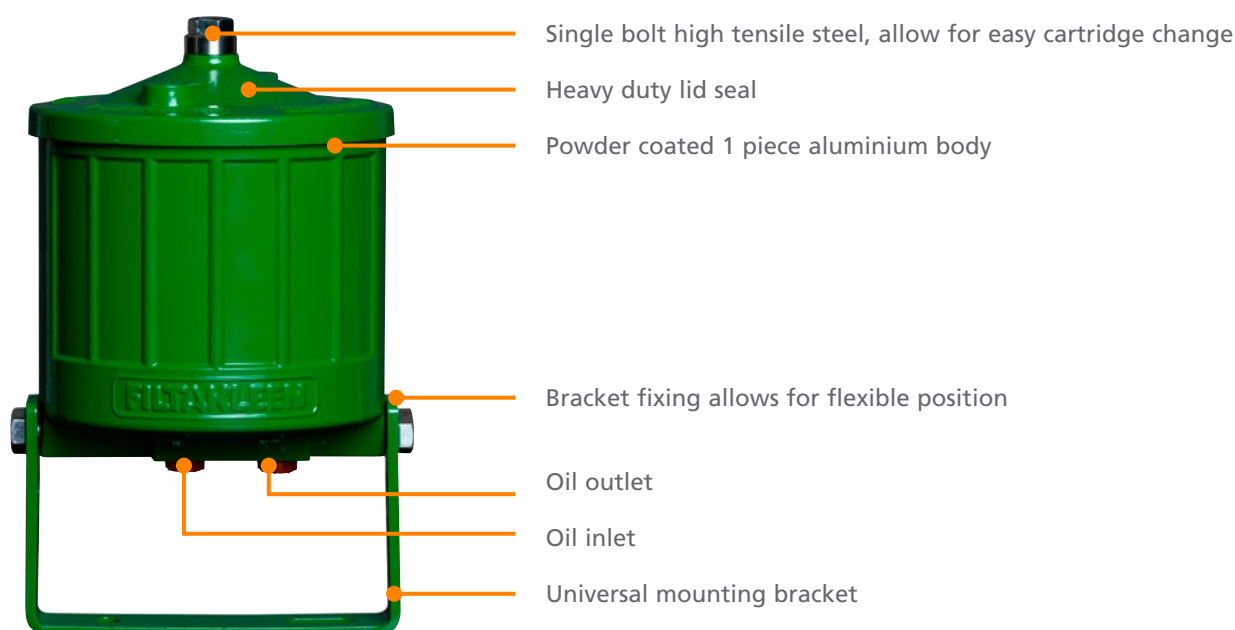

## Groeneveld Tecreel

The Tecreel range of self-retracting hose reels provides an efficient way of conveying hydraulic power from fixed to moving points on cranes, truck mounted cranes, telehandlers, lift trucks and container handling equipment. An integral coil spring ensures that the hoses remain constant under tension.

Reels are available as 2 port, 4 port and multi function models; each complemented by a choice of 2 or 4 port swivels providing 180° of free hose movement.

Tecreel eliminates slack or trailing hydraulic hoses where continuous variation of hose length is required, while transferring hydraulic oil to moving, rotating and swivelling parts.

The main benefits at a glance:

- Robust all steel construction
- Epoxy powder coated for increased wear resistance
- Reliable operation and maintenance free
- Available as reel only or with hoses

### Efficiently conveying hydraulic power

Tecreel is a non-locking, spring retractable hydraulic hose reel assembly, designed for use where movements occur requiring continuous variations in hose length. The Tecreel automatically rewinds the surplus hose under constant spring tension.

The Tecreel is suitable for almost all situations in which hydraulic power needs to be transferred from a fixed point to a moving point. Applications include forklifts, counter balance trucks, reach reachstackers, cranes with hydraulically controlled attachments, truck mounted cranes, telehandlers, container cranes and above ground mining applications.

### System overview

#### Powder coated

Tecreel hose reels are supplied with red or orange powder coat as a standard. Other colors are available upon request. Marine grade reels with additional corrosion protection are also available upon request.

#### Shaft inlet

There are various shaft inlet adaptors available.

#### Oilways

There are two separate oilways running through the hub & shaft assembly to allow oil to flow into the hub. They are separated by rotary seals.

#### Left-hand or right-hand mounting

All models can be supplied in both left-hand or right-hand mounting.

#### Hoses

Tecreel is available with and without hoses. Hoses are available in different hose bores and various hose lengths.

#### Connection ports

The hose connection ports on hose reel hub are 3/8" BSP. Adaptors fitted as standard are 3/8" male to 3/8" male.

Standard hose fitting is 3/8" BSP female compact 90° elbow. Other adaptors for different hose fittings are available on request.

#### Hose free-end fittings

Free ends of hose connected to attachment to be actuated.

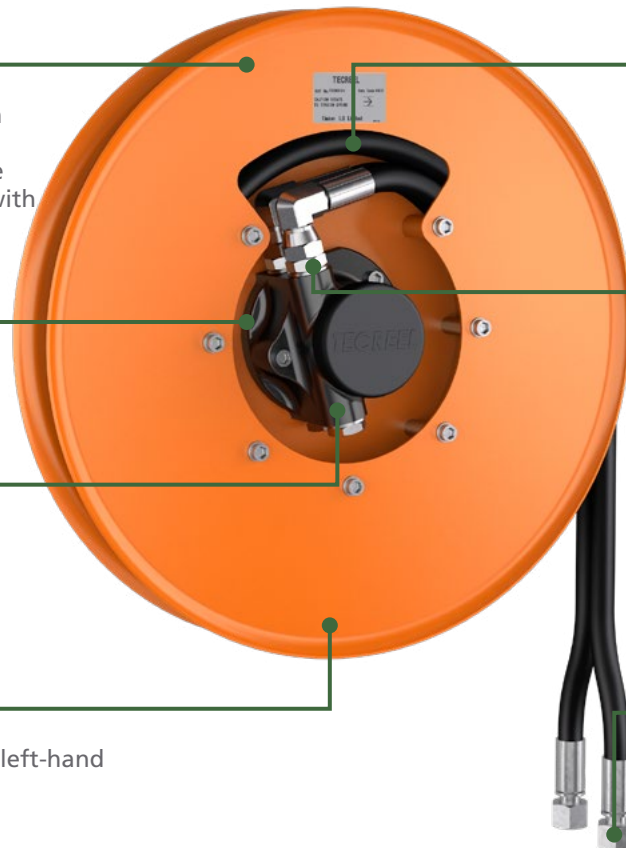

# **Safety support systems**

**Reduce risks, enhance safety**



## Greensight | Ultrasonic obstacle detection and camera system

The highest priority within different industries is safety. With large blind spots around mobile equipment and the tight time schedules, guaranteeing safety is a continuous challenge. The Greensight obstacle detection and camera systems offer an excellent solution to increase safety.

- Improved safety around the machine
- Less chance of damage
- Increased uptime
- Fully adjustable to the application and the customer's wishes
- Ultrasonic acoustic warning system
- Fully integrated and modular system
- Can be enhanced with a smart alarm

### Modular system

Greensight is available as an ultrasonic acoustic obstacle detection system, as a camera system and as a combination of both. The system can be set up modularly. Moreover, it is an integrated solution that can be adapted to the application perfectly.

#### Ultrasonic detection system

Thanks to the ultrasonic operation the system will detect obstacles in three pre-set zones very accurately. The system can also be extended with sensors either on the sides or on the top of a vehicle or machine. As soon as an obstacle is detected, an acoustic signal is sounded for the operator in the cab, so he can check on the display which zone the obstacle is in.

The detection zones can be adapted entirely according to the wishes of the customer and the working conditions, even when the system has been put into operation.

#### Camera system

The ultrasonic detection system can be extended with a high-quality camera system, which can improve the visibility for the operator significantly. This could be a solution for blind spots. Four cameras can be connected to the monitor, with all four of the camera images being able to be displayed on a split screen. The Groeneveld camera system can be used on its own, or in combination with the Greensight ultrasonic detection system – a combination that increases safety greatly.

### System overview

#### Camera

The Greensight system can be extended with up to 4 CMOS full color cameras. They are available with a 104° and 116° viewing angle.

The cameras have a high sensitivity of 0.025 lux, have an automatic heated lens and a temperature range of -40 °C up to +70 °C.

#### 7" Monitor

The Greensight monitor can show up to four cameras at the same time. The monitor is made of a sturdy material and has a high LCD luminance.

The TFT display has an automatic back-light control and will dim itself gradually depending on the ambient light level and system settings.

#### Additional sensor

Expanding the obstacle detection system by adding top or side sensors increases the detection area of the system.

#### Ultrasonic sensor

The Greensight ultrasonic sensors are based on military technology and therefore very sturdy.

The detection areas are adjustable and cover up to 97% of detection behind the application.



### 1. Control unit

The control unit is the core of each Greensight system. On this basis, each system can be built up modularly.

For smaller systems, a control unit with six connections is available. For more extensive systems, there is a control unit with 15 connections.

### 2. Sensors

The basic components of the Greensight ultrasonic detection system are the two sensors on the rear of the application. The sensors detect objects with a minimum dimension of 75 mm.

When an object is detected, the driver is alerted by means of distance dependent visual and audible signals on the in-cab display or monitor.

### 3. In-cab display

If the system is used without cameras, the in-cab display warns the driver by means of light and acoustic signals. Alerts become increasingly frequent as an object get nearer to the application.

### 4. Additional sensors

To expand the obstacle detection system, sensors are available to mount on top of or on the sides of the application.

By mounting two extra top sensors higher obstacles such as signs or half-open roller doors can be detected. The side sensors help prevent damage during complex manoeuvres.

### 5. Camera system

The obstacle detection system can be expanded with the a camera system. Up to 4 cameras can be connected to the system to reduce blind spots.

Unique characteristics:

- Clear and sharp view under all conditions
- No problems with condensation or frost due to automatically heated lens surface
- High sensitivity at 0.025 lux (good visibility with less light)
- Switches easily between different camera images

The camera system can also be used as an independent system.

### 6. Smart alarm

By adding a smart alarm, people located near the application are also warned as soon as Greensight observes them or an obstacle. An acoustic signal is given only when it is necessary, warning bystanders to stay alert.

The volume of the smart alarm is automatically adjusted depending on the amount of noise in the background.

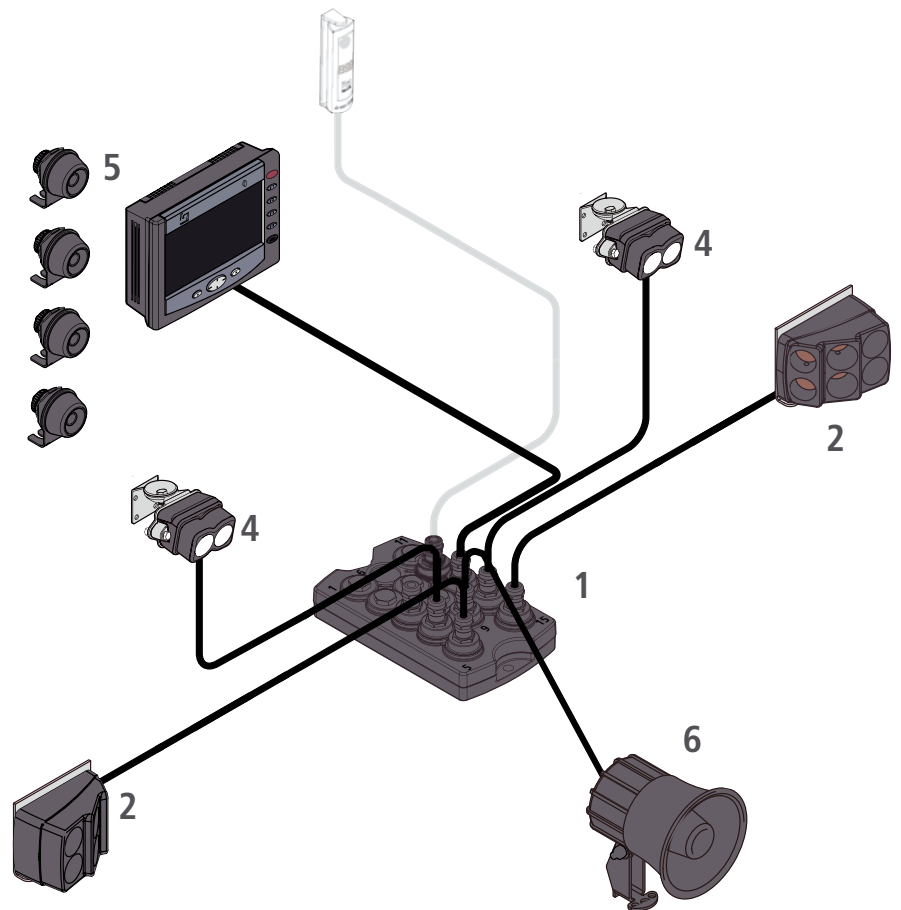

## Greensight | Radar obstacle detection and camera system

The highest priority within different industries is safety. With large blind spots around mobile equipment and the tight time schedules, guaranteeing safety is a continuous challenge. The Greensight obstacle detection and camera systems offer an excellent solution to increase safety.

- Improved safety around the machine
- Less chance of damage
- Increased uptime
- Fully adjustable to the application and the customer's wishes
- Radar obstacle detection with acoustic warning system
- Fully integrated and modular system

### Modular system

The Greensight radar obstacle detection and camera systems offers solutions for reducing blind spots around the vehicle with radar sensors, as a camera system or a combination of both. The modular range of radar sensors, cameras, monitors and recorders offer the possibility to improve safety, security and efficiency to suit the application best.

#### Radar detection system

Thanks to the radar technology, the system has a long detection range up to 20 or 40 meters, depending on the type of sensor. The radar will detect static and moving obstacles in a detection zone very accurately and will notify the driver or operator with an audible warning. The detection zones can be adapted entirely according to the wishes of the customer and the working conditions, even when the system has been put into operation.

#### Camera system

The detection system can be extended with a high-quality camera and monitor system, which can improve the visibility for the operator significantly. Up to four cameras can be connected to a monitor, with all four of the camera images being able to be displayed synchronously.

High-quality camera and monitors are available to cover the rear, side and front blind spots. Different cameras can be combined with different kinds of monitors to suit the application. Additionally a digital recorder can be added to the system, which can provide evidence in case of an accident.

### System overview



#### Radar system

The radar sensor is greatly helpful in alerting operators to avoid potential danger and take proper actions in advance. These radar sensors are built on millimeter wave technology and perform in all weather conditions.

It's very helpful for reversing or parking and widely used in large vehicles such as trucks, construction equipment, agricultural machinery and many more.

#### Cameras

The range of cameras varies from single rear or side view cameras with different viewing angles up to a complete 360° surround view camera system.



#### Monitors

Greeneveld-BEKA offers a range of monitors consisting of 7 and 10.1" monitors with different specifications.

#### Recorder

Separate DVRs are available for recording footage of up to 4 mounted cameras in high definition.

### Pedestrian detection camera

The pedestrian detection camera is especially developed to differentiate pedestrians from objects in real time to help make drivers more aware of pedestrians around a vehicle.



## Installation examples

The Greensight obstacle detection and camera systems can be applied on different applications.

### Ultrasonic obstacle detection and camera system

#### Top sensor

The top sensor increases the detection area behind the machine.



#### In-cab display

The in-cab display warns the driver by means of light and acoustic signals when an obstacle is detected.



#### Bottom sensor units

The ultrasonic sensors offer the driver information about the free space behind the machine.

### Radar obstacle detection and camera system

#### Front view camera

A front view camera provides the opportunity to look over a load or the bucket.



#### Rear view camera

A rear view camera lets you see the area immediately behind the machine. Not only safe reversing but also turning the machine.



#### Monitor

A high definition quad view monitor can display up to 4 cameras synchronously.



#### Radar sensor

Adding a radar sensor alerts operators for static and moving objects so they can take proper actions in advance.



Groeneveld-BEKA | [info@groeneveld-beka.com](mailto:info@groeneveld-beka.com) | [www.groeneveld-beka.com](http://www.groeneveld-beka.com)

*Despite every effort on our part, deviations from the illustrations or dimensions, calculation errors, printing errors or incomplete information in this brochure cannot be excluded. Groeneveld-BEKA accepts no liabilities for any inaccuracies and/or incompleteness in the content of the brochure. It is not permitted to continue to distribute the information published in this brochure without prior written permission from Groeneveld-BEKA, provided it is for personal use and solely for the purpose for which the information has been made available.*